

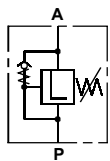

Sequence valve



Throttle check valve



Advantages:

- ✓ Compact design
- ✓ Simple mounting hole
- ✓ Valve combinations possible
- ✓ Unified insert contour
- ✓ Operation with one line possible
- ✓ Working pressure up to 400 bar
- ✓ Different settings
- ✓ All valves with integrated non-return valve

pressure media:

Hydraulic oil according DIN 51524 TI.1 to 3; ISO VG 10 to 68 acc. DIN 51519

Example

When pressure is applied from the hydraulic unit, cylinders **1+2** are moving out. Cylinder **2** moves out with a throttled speed, to compensate any volume differences.

If the cylinders **1+2** reach their end position, the pressure in the main line A (P) is increasing. If the pressure exceeds the set value of the sequence valve, cylinders **3+4** are coming out.

To cylinder **4** the inlet pressure less the setted pressure difference is transmitted via the differential pressure valve. Cylinder **4** generates less force because of the pressure difference.

If the pressure on the inlet side A (P) drops down, the check-valves allow free flow from B (R) to A (P) and the cylinders **1 to 4** return to their normal position.

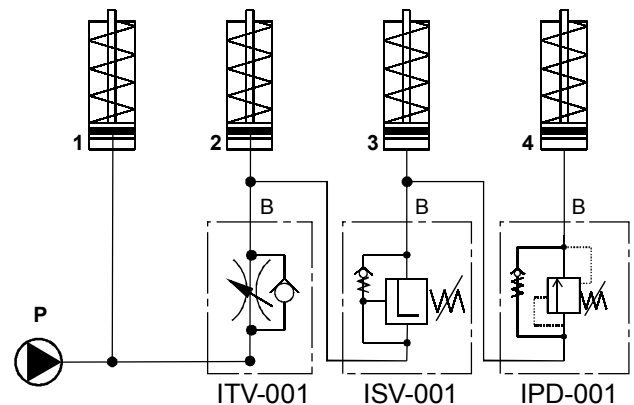

Throttle check valve

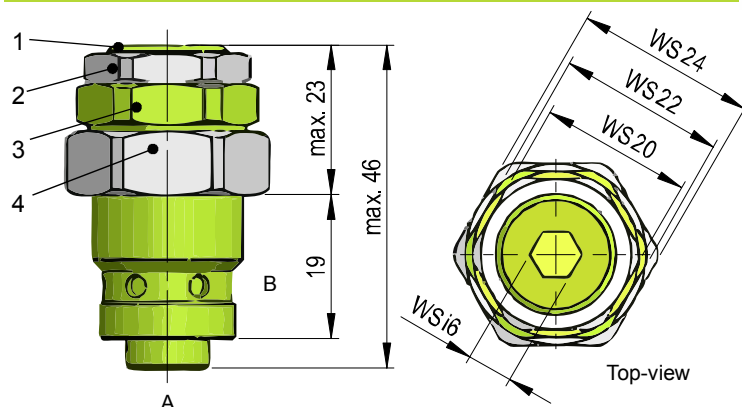

Part number: **ITV-001**

function:

Throttle check valves reduce the flow from A to B. The volume flow from B to A remains unchanged.

Note:

This valve is only available in this version.

- 1 = adjustment
- 2 = locknut
- 3 = valve body
- 4 = sealing nut

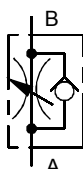

Insert-contour

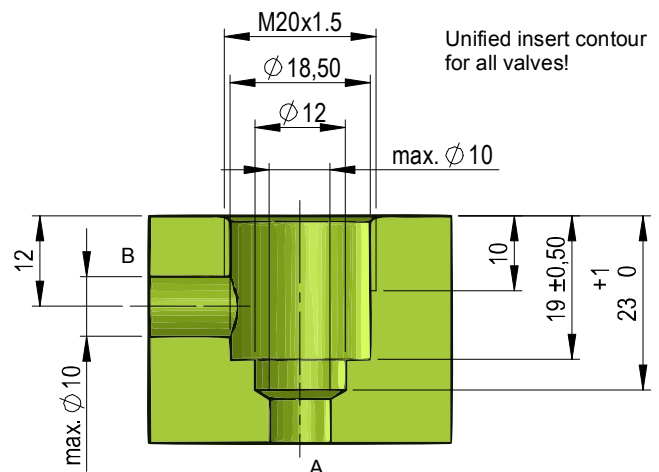

Contact

iNOSOL GmbH
Frankfurter Str. 18
35315 Homburg/Ohm (Germany)

web: www.inosol.solutions
email: info@inosol.solutions
tel.: (+49) 6633 / 368 95 25

Sequence valve with integrated check valve

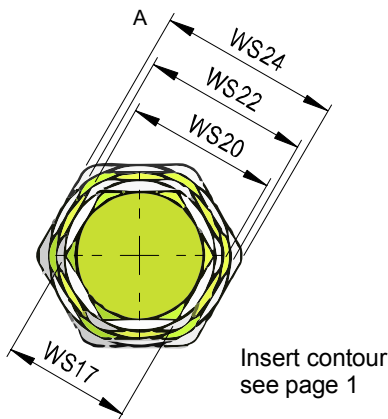
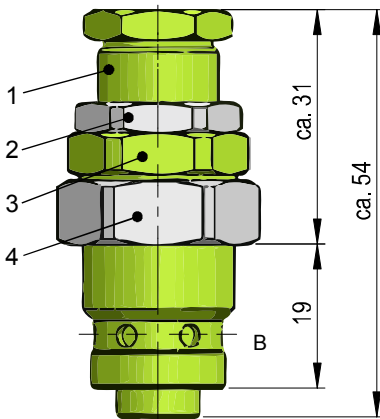

Sequence valve	Setting range	Pressure change per	Weight (g)	Thread
Part number	(bar)	rotation Δp (bar)		
ISV-001	0-80	10	90	M20x1,5
ISV-002	0-160	16	95	M20x1,5
ISV-003	0-300	36	100	M20x1,5
ISV-004	0-400	46	105	M20x1,5

Function:

Sequence valve with integrated check valve as directly operated poppet valve to 400 bar.

After reaching and exceeding the setted pressure value at the inlet side A (P), the sequence valve switches to full pressure on the load line B (R) (leak-free).
If the pressure on the inlet side A (P) drops down under the pressure of the load line B (R), the integrated non-return valve allows a free flow of B (R) to A (P).

The sequence valve may be used as a **pressure relief valve**.

If the pressure in hydraulic systems is reaching the setted pressure value on the inlet side A (P), the valve opens for the return flow line B (R), until the pressure in the hydraulic system drops below to the set pressure value.

Note:

Inlet and outlet pressure are always identical in the sequence valves.

As a result, this type of valve is ideal for use in sequential circuits.

Row combinations of sequence valves are possible.

1 = adjustment

2 = locknut

3 = valve body

4 = sealing nut

